

HYDRAULIC SCISSOR LIFT CART - EHLT-WS-2448-1.5-36

APPROX WEIGHT: 276.98 lbs.
 DOES NOT INCLUDE WEIGHT OF POWER OR PACKAGING!!!

*** ANY ADDITIONS, DELETIONS, OR OMISSIONS MUST BE CORRECTED ON THIS DRAWING AS THIS DRAWING WILL BE CONSIDERED ALL INCLUSIVE ***
 ALL GRAPHICS PROVIDED ARE FOR REFERENCE ONLY. IF CERTAIN DIMENSIONS ARE CRITICAL PLEASE VERIFY THOSE DIMENSIONS WITH YOUR SALESPERSON

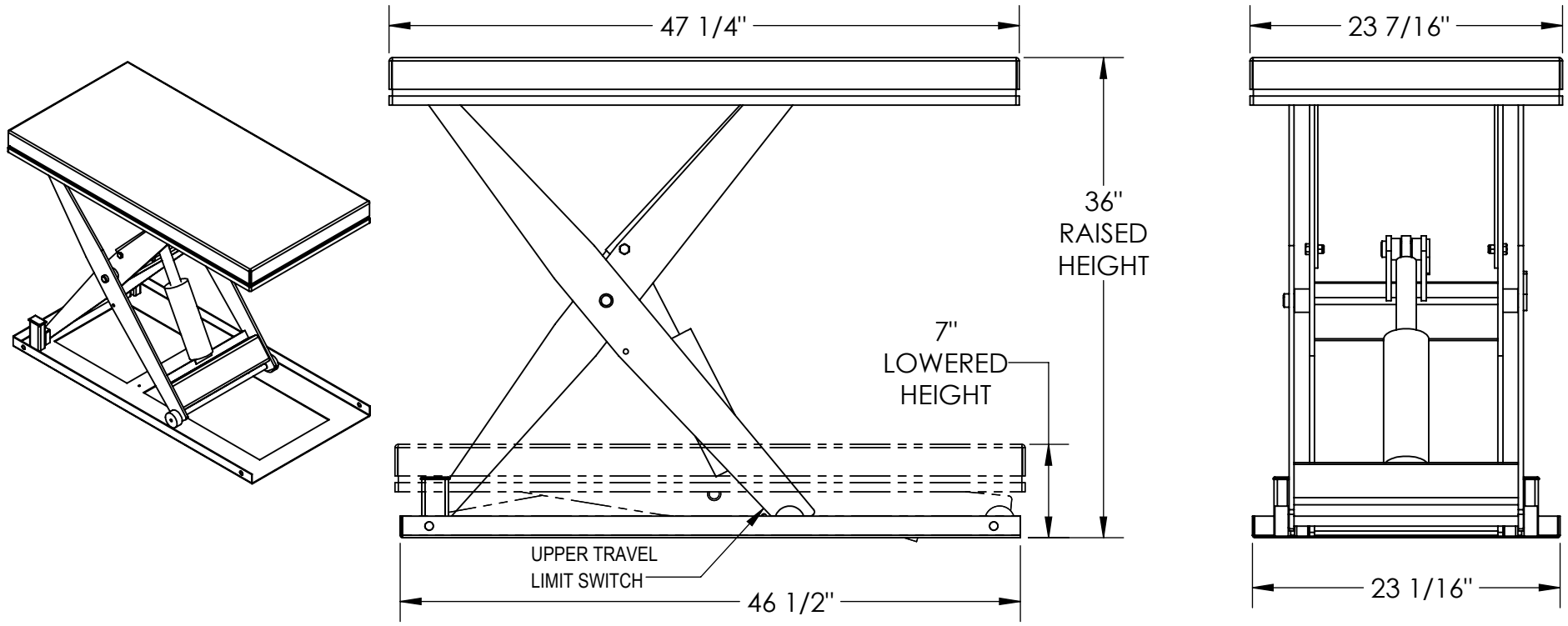

DIMENSION TOLERANCE ± 1/4"

STANDARD FEATURES

- MODEL NUMBER IS EHLT-WS-2448-1.5-36
- OVERALL WIDTH IS 23 7/16"
- OVERALL LENGTH IS 47 1/4"
- RAISED HEIGHT IS 36"
- LOWERED HEIGHT IS 7"
- TABLE CAPACITY (EVENLY DISTRIBUTED) IS 1,500 LBS.
- CONTROL IS HANDHELD 2 BUTTON, NEMA 4 PENDANT
- SAFETY MAINTENANCE PROPS, DISPLACEMENT
- STYLE CYLINDERS INSTALLED ROD DOWN
- EMERGENCY SAFETY STOP HYDRAULIC FUSES
- UPPER TRAVEL LIMIT SWITCH
- ELECTRIC PINCH POINT GUARD
- DURABLE LIQUID PAINT YELLOW FINISH

SPECIAL FEATURES

NONE

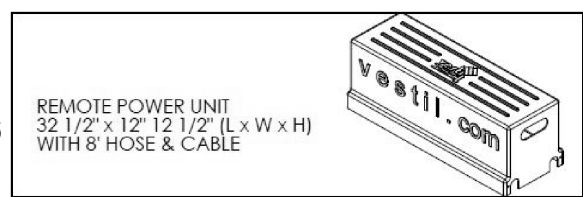

REMOTE POWER UNIT
 32 1/2" x 12" x 12 1/2" (L x W x H)
 WITH 8' HOSE & CABLE

APPROVAL

I, THE UNDERSIGNED, AGREE THAT THE PRODUCT AS REPRESENTED SATISFIES DESIGN AND DIMENSION REQUIREMENTS. I ALSO ACKNOWLEDGE MY DUTY TO CONFIRM PRODUCT AND INSTALLATION COMPLIANCE WITH ALL APPLICABLE FEDERAL, STATE AND LOCAL REGULATIONS AND STANDARDS.

UNITS REQUIRING APPROVAL DRAWINGS OR MODIFIED ARE NON-RETURNABLE

[] As drawn [] As marked

Signed: _____ Date: _____

Printed Name: _____

LEAD TIME WILL START UPON RECEIPT OF SIGNED APPROVAL DRAWING

POWER	AC	DC (12V)	AIR/OIL
MOTOR VOLTAGE	115	208	230 460
DEDICATED CIRCUIT REQUIRED 60Hz			
MOTOR PHASE	SINGLE	THREE	
CONTROL	HAND	FOOT	

DISTRIBUTOR'S NAME: _____

VESTIL MANUFACTURING

DRAWN BY: CRA DATE: 9/6/2023

REFERENCE: X SCALE: 1:12

QUOTED LEAD TIME: X QUOTE # X

P.O.# X
 W.O.# X
 SALES: X
 FILE NAME: 01-007-527-001